

## Features

- Control of up to three 230 VAC LED traffic light modules
- Two RS-485 serial communication interfaces, electrically isolated
- Communication protocol compliant with TLS 2012; other protocols available on request
- Continuous monitoring of loads and self-monitoring
- Power-off monitoring, monitoring of connections to the traffic light inserts even when switched off
- Special functional sequences such as flashing, interlocks and signal transitions
- Extended operating temperature range -20 to +70°C
- Control of dimming function for traffic light inserts (not available for all inserts)
- CAN interface for external extensions e.g. input/output expansion module

## Applications

- Serial control and monitoring of LED traffic lights via the TLS protocol (integration into „variable traffic sign“ environment)
- Extension of local traffic light functions with signal monitoring, signal transition control, flashing mode and dimming
- Flasher synchronisation via serial communication

## Function description

The traffic light controller is a universal interface between a modern signal control system based on serial connections and conventionally operated LED traffic lights. The TLC-003 can control up to three LED traffic light modules, corresponding to a 3-chamber traffic light. Provided the LED modules support this, their brightness can be reduced using a single-stage voltage reduction.

The RS-485 serial interfaces and the CAN interface are galvanically isolated and protected against overvoltage. Serial data communication is based on the TLS-2012 standard protocol.

The loads are monitored via continuous current measurement both when the system is switched on and off, and any detected faults are reported. This



means that even when the signal is switched off, it is possible to determine whether an LED module is present, whether there is a cable break, or whether a LED module is faulty.

An external I/O module can be connected via the CAN interface, which can be used to implement local, manual gate- or emergency control.

## Easy installation

The TLC-003 module is mounted directly onto a 35 mm DIN rail or screwed to the rear panel using optional side brackets.

## Connection

All connections are made via two detachable 8-pin connectors. The upper connector hosts all 230 V AC connections while the lower hosts the communication connections.

## Block diagram

The block diagram shows the functional blocks and connections to the traffic light modules and the control unit. The TLC-003 is controlled by one of the RS-485 interfaces. The second RS-485 interface can optionally be used, for example, for serial control by

# Signal Controller for LED Traffic lights

## TLC-003

04/26

an additional, redundant system. The traffic light modules are controlled using wear-free, electronic switching elements. This ensures long-term, low-maintenance operation.

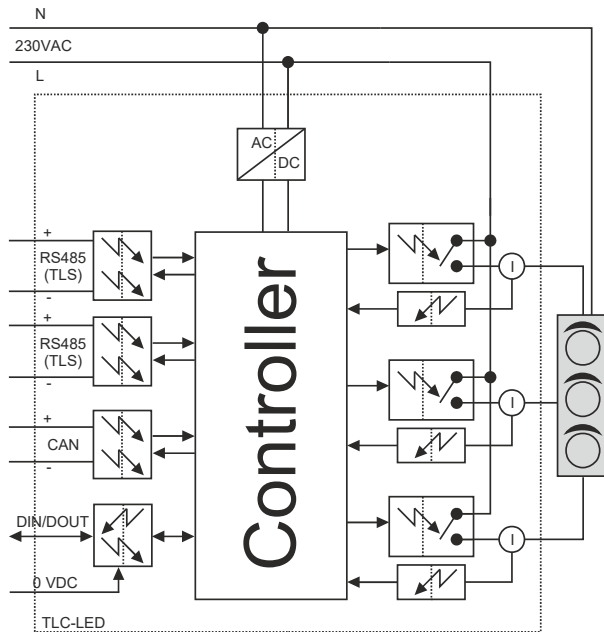

Block diagram of the TLC-003 traffic light controller

## Technical Specifications

### Mechanics

**Mechanical:** Housing 75 x 45 mm, depth 123 mm  
**Assembly:** (measured without connectors)  
**Mounting:** Mounting on 35 mm DIN rail or by using side brackets  
**Connections:** 2 detachable connectors, each with 8 contacts  
**Indicators:** Status, communication and switching position indicator LEDs

### Connections

**Power supply:** 1 x L, N + PE  
**Traffic light modules:** 3 x L, N + PE  
**Communication:** 2 x RS-485 (A/B)  
 1 x CAN (H/L)

### Electrical Specifications

**Supply voltage:** 230 VAC  $\pm$  10%  
**Power consumption:**  $\leq$  5 Watt  
**Serial interfaces:** RS-485 and CAN, galvanically isolated (shared)  
**Traffic light output:** 230 VAC in normal operation  
 (Nominal values) 160 VAC in dimmed operation  
**Output current:** 70 mA per channel (Maximum values)  
 180 mA total for all channels

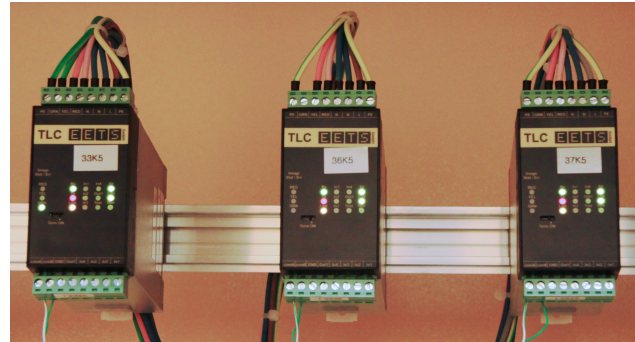

TLC-003 mounted on a DIN rail inside a cabinet

### Communication

Data communication is based on the TLS protocol, version 2012. Manufacturer-specific extensions provide additional functions such as blinker synchronization.

### Cable Length

The cable length between the Signal Controller TLC and the traffic signal modules must not exceed the maximum length that guarantees the voltage at the modules, including power supply tolerance, meets the following minimum value:

Voltage at traffic light module: 195 VAC in normal operation

### Environment

**Operating temperature:** -20°C to +70°C  
**Storage temperature:** -40°C to +80°C  
**Humidity:** up to 90%, non condensing

### Supported traffic light types

FuturLED-3/6 \* 230 VAC 200 mm and 300 mm  
 \* with and without dimming

### Delivery Contents

TLC-003, two connectors

### Options

- I/O expansion module (via CAN)
- Bus termination module for serial interfaces
- Test and configuration tool for PC

### EETS GmbH

Chaltenbodenstrasse 6E  
 CH-8834 Schindellegi (SZ)  
 Switzerland

**Phone:** +41 44 687 68 10  
**email:** info@eets.ch  
**Internet:** [www.eets.ch](http://www.eets.ch)

